



Conversion instructions from natural gas to propane Logano GC 144 II

Contents

1	Safety considerations	2
1.1	Key to symbols	2
1.2	Safety instructions	2
2	Product information	3
2.1	Correct use	3
2.2	Scope of delivery	3
3	Conversion to propane	3
4	Start-up instructions	6
4.1	Starting up boiler	6
4.1.1	Prepare pressure measurement	6
4.1.2	Turning on heating system	6
5	Final start-up procedures	7

1 Safety considerations

1.1 Key to symbols

Warnings



Warnings in this document are identified by a warning triangle printed against a grey background. Keywords at the start of a warning indicate the type and seriousness of the ensuing risk if measures to prevent the risk are not taken.

The following keywords are defined and can be used in this document:

- **NOTICE** indicates a situation that could result in damage to property or equipment.
- **CAUTION** indicates a situation that could result in minor to medium injury.
- **WARNING** indicates a situation that could result in severe injury or death.
- **DANGER** indicates a situation that will result in severe injury or death.

Important information



This symbol indicates important information where there is no risk to people or property.

Additional symbols

Symbol	Explanation
▶	Step in an action sequence
→	Cross-reference to another part of the document
•	List entry
–	List entry (second level)

Table 1

1.2 Safety instructions

Risk to life through the explosion of volatile gases

- ▶ Work on gas components must be carried out by qualified and authorized personnel only.

Risk to life from electric shock.

- ▶ Disconnect the power supply to the heating system before conducting any work on it, e.g. switch off the heating emergency switch outside the boiler room.
- ▶ It is not sufficient just to switch off the control.

2 Product information

2.1 Correct use

This conversion kit and the accompanying instructions are for conversion of GC 144 II special gas-fired boilers from natural gas to propane.

Requirements

GC 144 II-18 74 MBtu/hr	GC 144 II-25 103 MBtu/hr	GC 144 II-32 132.5 MBtu/hr
----------------------------	-----------------------------	-------------------------------

Table 2 Requirements

2.2 Scope of delivery

- Honeywell gas solenoid valve conversion kit # 393 691, comprising:
 - black safety screw
 - pressure adjustment screw
 - red spring
 - yellow label for gas valve
- GC 144 II: BBR 12 pilot gas orifice
- Main gas orifices and seals
- "Conversion to propane" label (to be filled out and attached to the unit)
- Technical documents

3 Conversion to propane

For your own safety read the instructions before conversion.



WARNING: Risk to life through not observing the conversion instructions.

- ▶ If you wish to convert the boiler for operation with propane, the conversion from natural gas to propane must be carried out first as specified by the attached conversion instructions.

The following instructions must be followed for conversion of the boiler to propane:

- ▶ If the boiler was in operation, close the gas shut-off. Otherwise open boiler front door.
- ▶ Set room thermostat (optional) to the lowest value.
- ▶ Disconnect the heating system from the power supply.
- ▶ Open boiler front door.

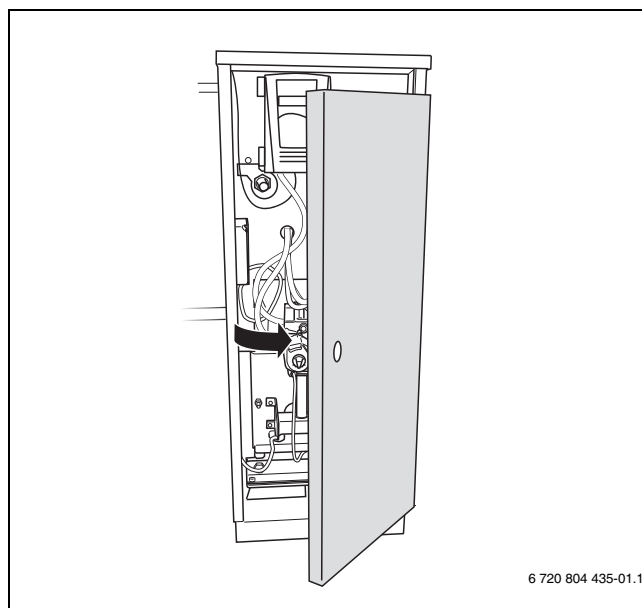

Fig. 1 Opening boiler front door



WARNING: Risk to life through fire or explosion.

- ▶ Never use excessive force on the ON/OFF knob (→ figure 2).
- ▶ Turn ON/OFF knob only by hand.
- ▶ Never use tools to turn knob.
- ▶ If you are unable to turn the knob by hand, do not try to repair it.
- ▶ Call Buderus technical service for assistance.

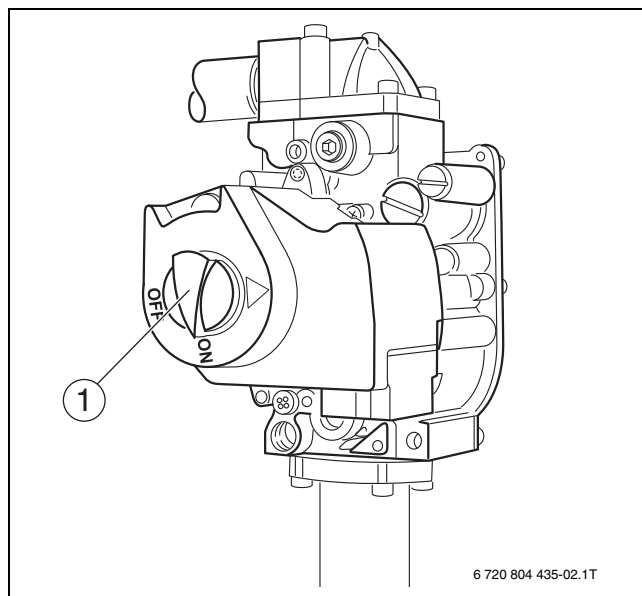

Fig. 2 Gas valve

[1] ON/OFF knob (shown in ON position)

- ▶ Turn gas valve ON/OFF knob clockwise to OFF position. Do not use force.



WARNING: Risk to life through the explosion of volatile gases.

► Wait five (5) minutes until all gas residues have dissipated. Check whether there is any smell of gas, including at floor level. If you can smell gas, close the gas shut-off and disconnect the heating system from the power supply and contact the customer service technician or the gas company.

► If there is no sign of a gas odor, continue with the next step.

Removing burner

- Secure gas manifold with wire or cord.
- Remove igniter cable from ignition module (→ figure 3, [6]).
- Disconnect cable connector from bottom of gas valve (→ figure 3, [3]).
- Label cables to the flame roll-out switch, then remove cable (→ figure 3, [2]).

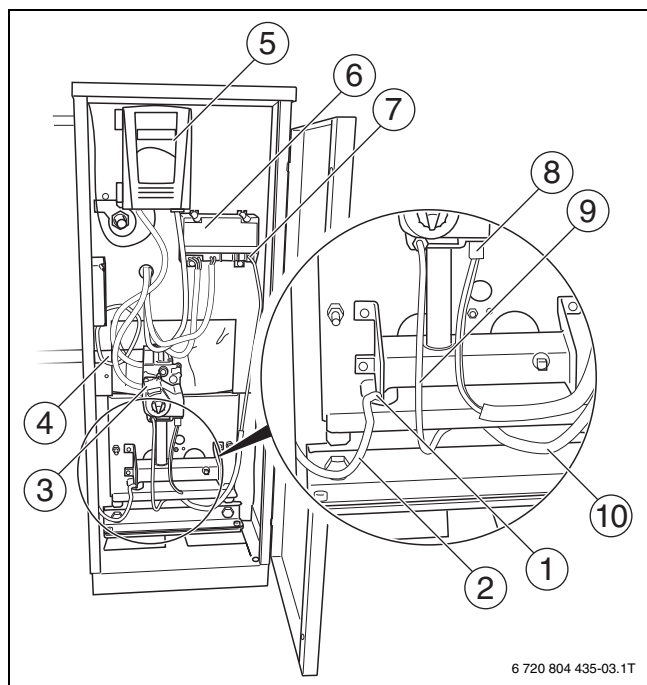

Fig. 3 Front view

- [1] Flame roll-out switch
- [2] Flame roll-out switch cable
- [3] Gas valve
- [4] Gas supply pipe
- [5] Aquastat
- [6] Ignition module
- [7] Igniter cable
- [8] Gas valve cable connector
- [9] Pilot line
- [10] Igniter cable

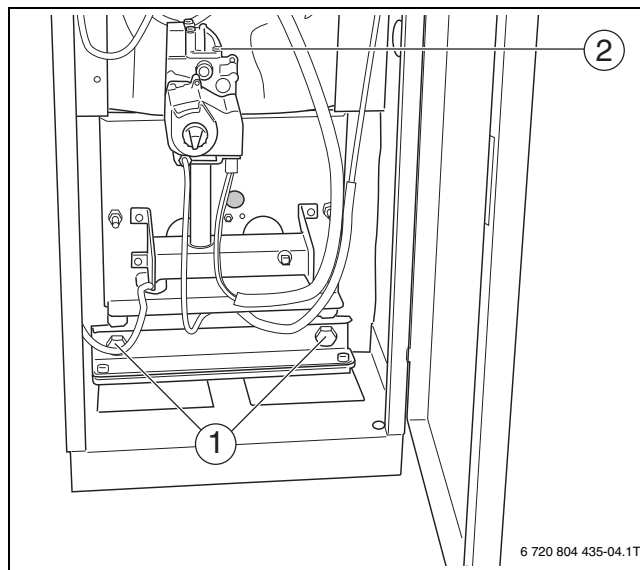

Fig. 4 Removing burner

- [1] Screw nuts (two)
- [2] Screws on gas manifold on top of gas valve (four)
- Remove four (4) screws from gas manifold on top of gas valve.
- Remove two (2) screw nuts on burner tray and take out the tray.

Replacing main gas orifices

- Install the new main gas orifices and copper gasket. Check with table 3 that the correct orifices for operation of the boiler are installed.



These orifice sizes are exclusively for installations 0-8500 feet above sea level.

Orifice sizes for propane			
Model	GC 144-18	GC 144-25	GC 144-32
Orifice size	180	175	170
Qty	2	3	4

Table 3 Orifice sizes for propane
These values are applicable for the U.S.A. only.
for altitudes of 0 - 8500 ft.

Converting gas valve

- ▶ Remove the safety screw [1] for the manifold pressure adjustment on the gas valve.
- ▶ Remove manifold pressure adjustment screw [2].
- ▶ Remove stainless steel spiral spring [3].
- ▶ Install the red spring from the Honeywell conversion kit in the gas valve.
- ▶ Screw in the new gas adjustment screw from the Honeywell conversion kit until it is flush with the top of the gas valve. Then screw the manifold pressure adjustment screw six (6) revolutions clockwise. This corresponds to a pressure preset of approx. 10.0 W.C. This setting must be checked with a pressure gauge on completion of the conversion (→ chapter 4, page 6).
- ▶ Install new black safety screw from the Honeywell conversion kit.
- ▶ Clean the gas valve housing [4] and attach the yellow label [5] from the Honeywell LP conversion kit to a visible spot on the gas valve.

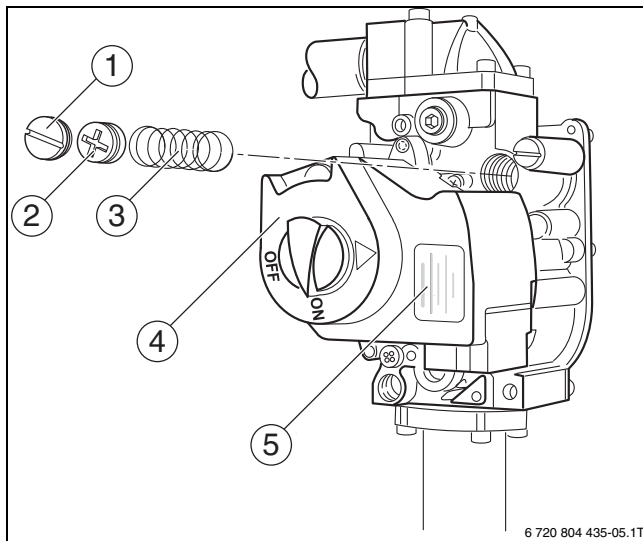

Fig. 5 Gas valve

- [1] Safety screw
- [2] Manifold pressure adjustment screw
- [3] Stainless steel spiral spring
- [4] Gas valve
- [5] Yellow label

Removing pilot burner and replacing pilot gas orifice

- ▶ Unscrew ignition burner unit from burner.
- ▶ Remove pilot orifice.
- ▶ Position the new BBR 12 pilot gas orifice in pilot burner unit.



When installing the pilot gas orifice, make sure that the pilot gas orifice is correctly threaded and tightened.

- ▶ Screw the pilot line to the pilot burner unit.
- ▶ Screw the pilot burner unit to the main burner.
- ▶ Check that the pilot burner unit is correctly seated compared to the main burner.
- ▶ Record the required information on the conversion label and attach on the outside of the boiler jacket as close as possible to the nameplate.

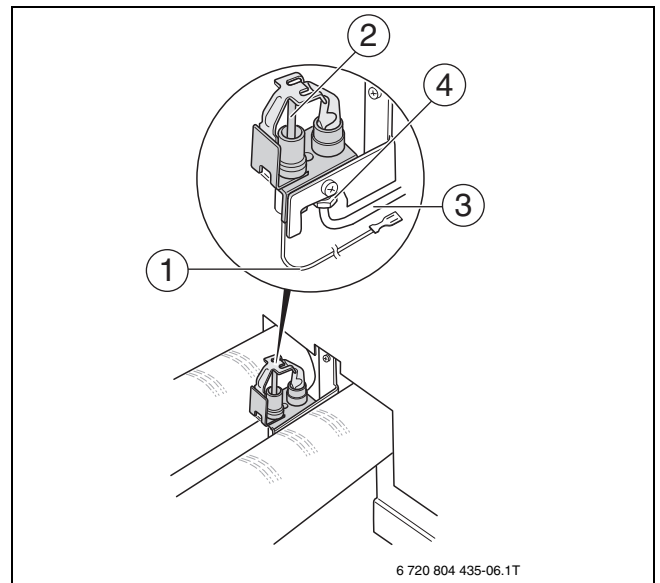

Fig. 6 Pilot burner

- [1] Ignition cable
- [2] Ignition electrode
- [3] Pilot gas line
- [4] Pilot gas line retaining screws

Carrying out leak test

- ▶ Open manual gas shut-off in the gas line.
- ▶ Check the gas supply line to the gas shut-off for leaks with soap solution. If no leaks are found, continue with the step after the next step. If any leaks were found, close gas shut-off.
- ▶ Seal leaks and repeat the previous step.
- ▶ Wait five (5) minutes until all gas residues have dissipated. Then check for a gas odor, including at floor level, because many types of gas are heavier than air.
- ▶ Always follow the start-up instructions on the next page.

4 Start-up instructions

For your own safety, read before boiler start-up.



WARNING: Risk to life due to not observing the start-up instructions and resulting malfunction.

- ▶ If these instructions are not followed exactly, fire or explosion may result causing serious property damage, loss of life, or serious personal injury.
- ▶ Observe the installation instructions.



WARNING: Danger of explosion
If you smell gas there is danger of explosion!

- ▶ No open flame! No smoking!
- ▶ Prevent spark generation. Never operate electrical switches, including telephones, plugs or door bells!
- ▶ Close main gas shut-off!
- ▶ Open windows and doors!
- ▶ Warn all occupants of the building!
- ▶ Evacuate the building!
- ▶ Call gas company, heating contractor or fire department from outside the building.



This unit is equipped with an automatic igniter that starts the burner. Do not attempt to ignite the burner manually.



WARNING: Risk to life due to water damage.

- ▶ Do not operate the unit if any part is or was submerged in water.
- ▶ Contact a qualified customer service technician immediately to have the unit checked and all parts of the control and gas valves replaced that were in contact with water.

4.1 Starting up boiler

- ▶ STOP! First perform a leak test as described on page 5 of this manual.
- ▶ First read the safety instructions on this page.

4.1.1 Prepare pressure measurement

- ▶ Remove the screw plug for the gas pressure measurement port on the gas valve. Install pressure measuring nipple and attach a pressure gauge to measure the gas pressure.
- ▶ Remove the screw plug for the orifice pressure measurement port on the gas valve. Install pressure measuring nipple and attach a pressure gauge to measure the orifice pressure.
- ▶ Open gas shut-off.

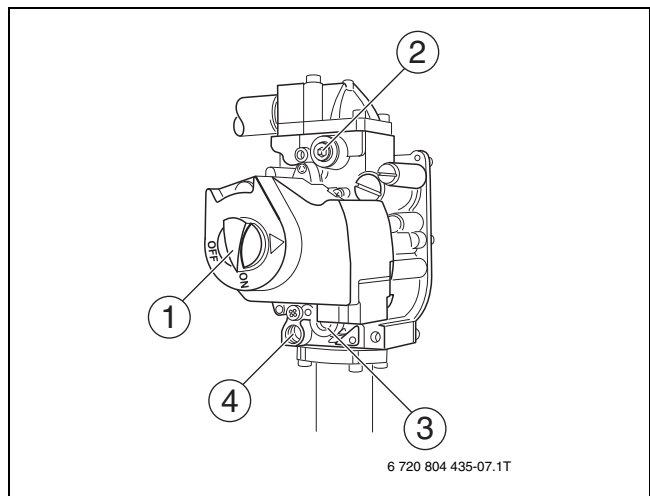

Fig. 7 Gas valve

- [1] ON/OFF knob (shown in ON position)
- [2] Screw plug for gas pressure measurement port
- [3] Screw plug for orifice measurement port
- [4] Ignition gas line connection

4.1.2 Turning on heating system

The boiler is fully functional with the factory-installed aquastat and field installed and connected vent damper.

- ▶ Switch on power to the heating system, continue to chapter 5 (→ page 7).
- ▶ Verify that the thermostat (optional) signals a heat demand to the boiler (set temperature dial at least 10°F above ambient).

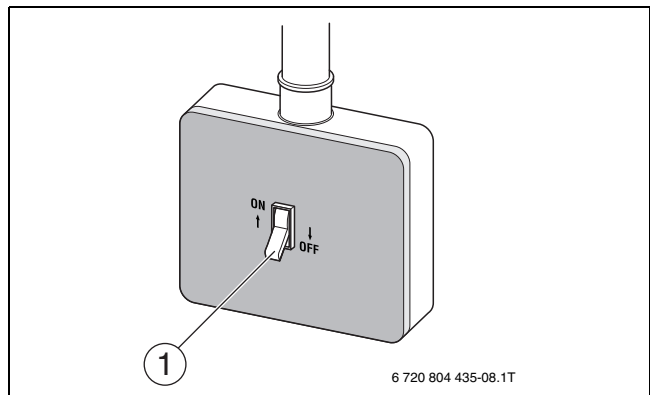

Fig. 8 ON/OFF switch

- [1] Emergency shutoff switch

5 Final start-up procedures

Verifying the ignition spark

- ▶ Look through the sight glass at the igniter and verify that a spark is visible.

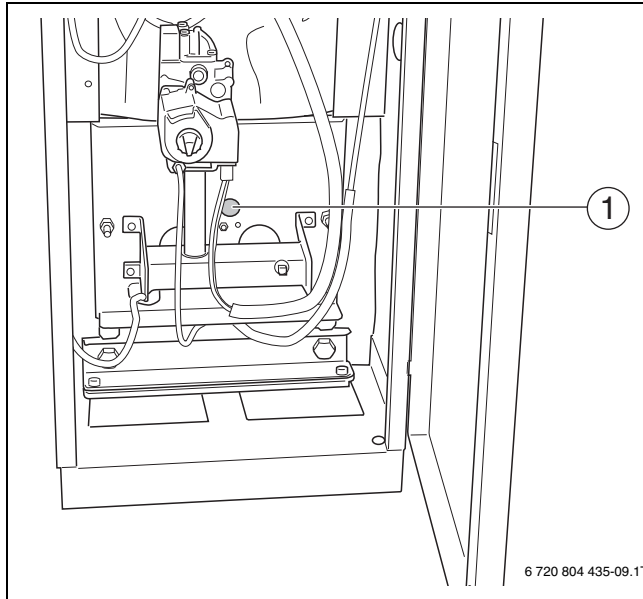

Fig. 9 GC 144 II

[1] Sight glass

- ▶ Should no spark be visible continue to troubleshooting procedure in the installation and service manual.



WARNING: Risk to life from fire or explosion.

- ▶ Never use excessive force on the ON/OFF knob (→ figure 10).
- ▶ Turn ON/OFF knob only by hand.
- ▶ Never use tools to turn knob.
- ▶ If you are unable to turn the knob by hand, do not try to repair it.
- ▶ Call Buderus technical service for assistance.

- ▶ Turn ON/OFF knob (→ figure 10) counterclockwise to the ON position.
- ▶ The ignition flame will appear and ignite the main burner. If the main burner does not ignite, close the gas shut-off. Disconnect heating system from the power source and inform your customer service technician or gas company.

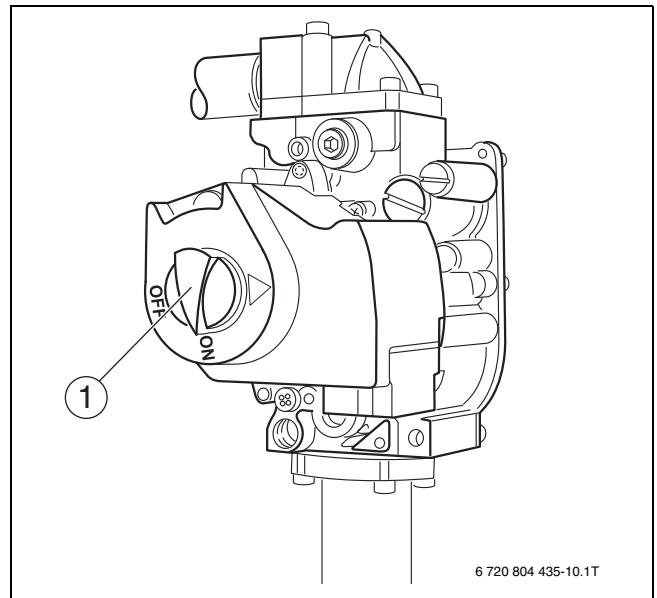

Fig. 10 Gas valve

[1] ON/OFF knob (shown in ON position)

Checking gas supply pressure

- ▶ Check the gas supply pressure while the boiler is operating. The connection pressure for natural gas must be between 4.7" and 10.5" W.C. For propane gas (LP) it must be between 11" and 13" W.C. If the gas pressure is in the correct range, record the measured value in the start-up protocol, then continue with the next step. If the supply pressure does not meet the above criteria, close gas line and contact the gas company.

Checking orifice pressure

- ▶ Compare the orifice pressure with the values in table 4. If it differs by more than 0.2" W.C., adjust accordingly. To set the orifice pressure, the protective screw on the gas valve must be removed (→ figure 11, page 8). Turn the adjustment screw clockwise to increase the pressure, and counterclockwise to reduce the pressure. This setting must be adjusted while the boiler is operating.

GC 144 II	Natural Gas [inch W.C.]	LP [inch W.C.]
18	3.5	8.8
25	3.5	8.6
32	3.5	8.7

Table 4 Orifice pressure at 60°F / 30" Hg. These values are only valid in the U.S.A. and only for elevations from 0-8500ft.

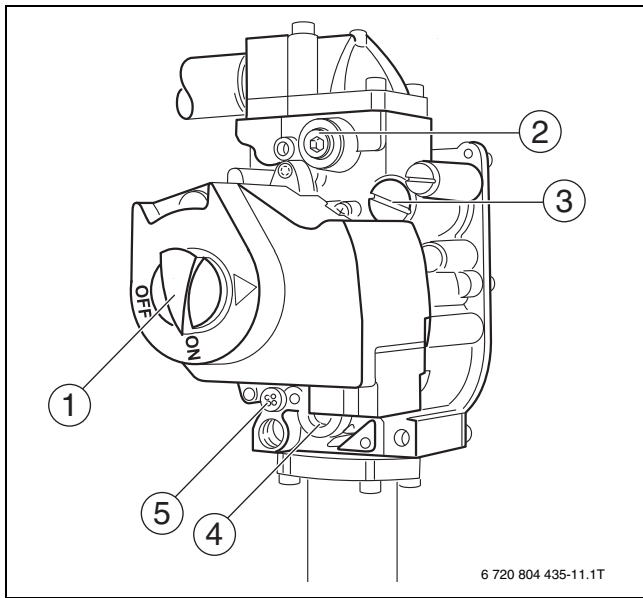

Fig. 11 Gas valve

- [1] ON/OFF knob (shown in ON position)
 - [2] Safety screw on gas supply pressure measurement port
 - [3] Safety screw on orifice pressure adjustment port
 - [4] Safety screw on orifice pressure measurement port
 - [5] Safety screw on ignition gas adjustment screw
- ▶ Record the measured value in the start-up protocol. Install the safety screw back into the gas valve.
 - ▶ Observe main burner flame through the sight glass (→ figure 9, page 7) in the burner plate. The flame must show a steady and stable body and generally be of bluish color. If the main burner flame meets the requirements, continue with the next step. If the main burner flame is weak, yellow, or goes out, turn the ON/OFF knob (→ figure 13, page 8) on the gas valve clockwise to OFF. Close the gas shut-off and disconnect the heating system from the main power source and contact the customer service technician or the gas company.

Checking flame rod

- ▶ Test the flame rod by closing the gas shut-off. The main burner flame (→ figure 12, page 8) and the ignition flame are extinguished. After no more than six (6) seconds the main gas solenoid valve on the gas valve must close with an audible noise. If the gas valve does not operate correctly, turn ON/OFF knob on the gas valve clockwise to the OFF position immediately. Close the main gas shut-off and disconnect the heating system from the main power source and contact the customer service technician or the gas company.
- ▶ After 90 seconds the igniter stops generating sparks for five (5) seconds.
- ▶ Disconnect the heating system from the main power source. Open main gas shut-off. A normal operating cycle must follow.
- ▶ If the main burner flame lights and burns to spec, continue with the next step. If not, turn knob on gas valve clockwise to OFF position immediately. Close main gas shut-off. Disconnect heating system from the power source and inform the customer service technician or gas company.
- ▶ Turn gas valve ON/OFF knob clockwise to OFF position.
- ▶ Close main gas shut-off.
- ▶ Disconnect heating system from the power source and set the thermostat to the lowest setting.

- ▶ Remove pressure measuring nipple and pressure gauge for measuring gas pressure and orifice pressure from the gas valve, and close the openings with the screw plugs.

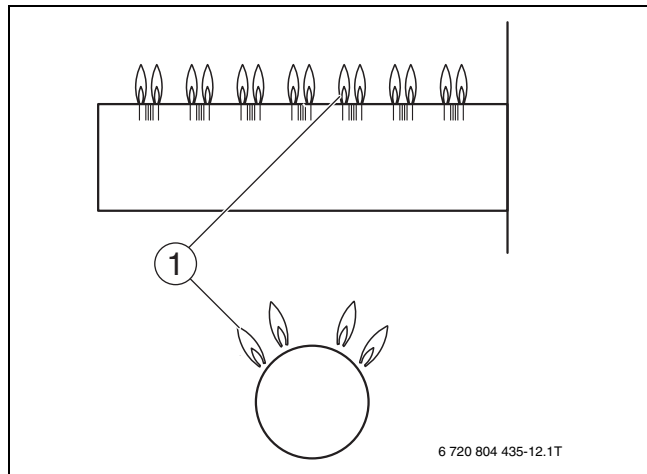

Fig. 12 Main burner

- [1] Main burner flame

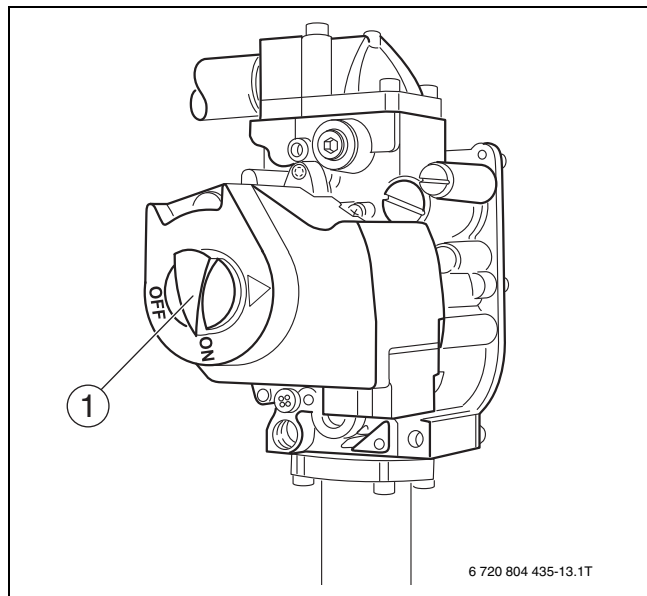

Fig. 13 Gas valve

- [1] ON/OFF knob (shown in ON position)

Checking for leaks

- ▶ Open main gas shut-off.
- ▶ Set thermostat at least 10°F above ambient to establish a heat demand.
- ▶ Turn main power switch ON.
- ▶ Turn gas valve ON/OFF knob counterclockwise to ON position.
- ▶ After the burner has lit check the gas valve including screw plugs for leaks using soapy water. If no leaks are found, continue with the step after the next step. If leaks are found, close gas shut-off and turn ON/OFF knob on gas valve clockwise to the OFF position. Disconnect the heating system from the power source and turn thermostat to its lowest setting.
- ▶ Seal leaks. Repeat all steps in this paragraph.

- ▶ Carefully wipe away the soapy water to prevent corrosion caused by the alkaline content of the soap.

Checking the vent damper



WARNING: Risk to life due to leaking flue gases.

- ▶ Verify the functionality and operability of the vent damper.

- ▶ Check the position of the vent damper. The damper must be fully open (vertical). When burner is on flue gases must not escape from the open draft hood.

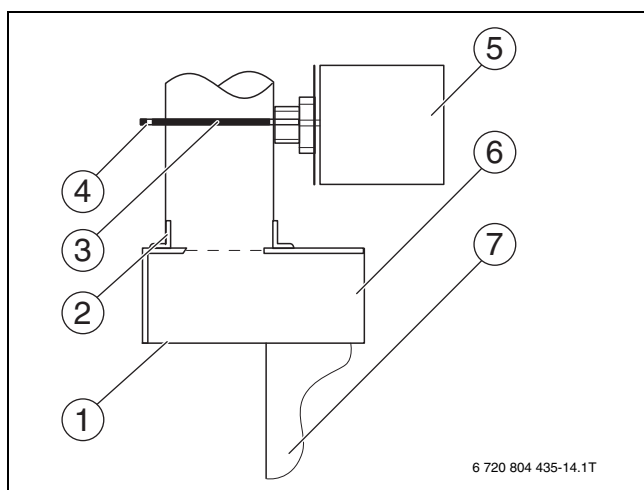

Fig. 14 Checking vent damper

- [1] Open draft hood
- [2] Vent connection
- [3] Vent damper
- [4] Damper blade position indicator
- [5] Vent damper motor
- [6] Flue gas collector
- [7] Boiler

Checking aquastat

Check the function of the maximum aquastat to make sure that it switches the boiler off as soon as the boiler water temperature set at the aquastat is reached. Record the result in the start-up protocol.

- ▶ Set aquastat to its desired setting.

- ▶ Replace front door and close.

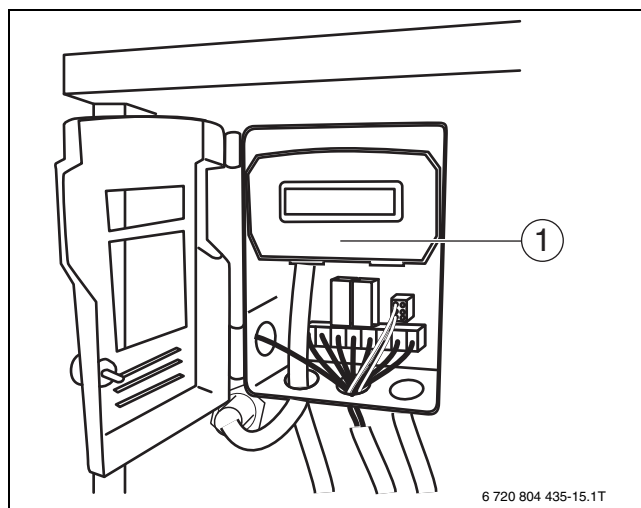

Fig. 15 Checking temperature control

- [1] Adjustment keypad

Notes

Notes

United States and Canada

Bosch Thermotechnology Corp.
50 Wentworth Avenue
Londonderry, NH 03053
Tel. 603-552-1100
Fax 603-965-7581
www.buderus.us
U.S.A.

Products manufactured by
Bosch Thermotechnik GmbH
Sophienstrasse 30-32
D-35576 Wetzlar
www.buderus.com

Bosch Thermotechnology Corp. reserves the right
to make changes without notice due to continuing
engineering and technological advances.

Buderus